



Hi-pot Type Testing

Application Note

This Application Note was written to provide insight into the one time requirement for 'type' testing of power supplies by the safety agency or manufacturer. It will assist in the interpretation of requirements for this testing and provide broad guidelines on exactly what is required of the manufacturer in this test procedure.

This application note is written primarily with regards to Class I power supplies that have a safety earth ground. At the end of the document there is a section that outlines the differences for Class II power supplies.

THE INFORMATION GIVEN IN THIS APPLICATION NOTE IS GIVEN AS A GUIDE ONLY FOR THE IMPLEMENTATION OF VOX POWER PRODUCTS AND SHALL NOT BE REGARDED AS ANY DESCRIPTION OR WARRANTY OF A CERTAIN FUNCTIONALITY, CONDITION OR QUALITY OF VOX POWER PRODUCTS. THE RECIPIENT OF THIS APPLICATION NOTE MUST VERIFY ANY FUNCTION DESCRIBED HEREIN IN THE REAL APPLICATION. VOX POWER HEREBY DISCLAIMS ANY AND ALL WARRANTIES AND LIABILITIES OF ANY KIND (INCLUDING WITHOUT LIMITATION WARRANTIES OF NON-INFRINGEMENT OF INTELLECTUAL PROPERTY RIGHTS OF ANY THIRD PARTY) WITH RESPECT TO ANY AND ALL INFORMATION GIVEN IN THIS APPLICATION NOTE. NO LICENSE, EXPRESS OR IMPLIED, BY ESTOPPEL OR OTHERWISE, TO ANY INTELLECTUAL PROPERTY RIGHTS IS GRANTED BY THIS DOCUMENT OR BY ANY PRODUCTS OF VOX POWER LTD.

VOX POWER LTD DISCLAIMS ALL WARRANTIES AND REPRESENTATIONS OF ANY KIND WHETHER EXPRESS OR IMPLIED, INCLUDING, BUT NOT LIMITED TO, IMPLIED WARRANTIES OF SUITABILITY, FITNESS FOR PURPOSE, MERCHANTABILITY AND NON-INFRINGEMENT.

Insulation Types

Figure 1 below represents a typical power supply from the standpoint of insulation systems.

- Between Primary and Secondary, reinforced insulation is required
- Between Primary and Chassis Ground, basic insulation is required
- Between Secondary and Chassis Ground, operational insulation is required

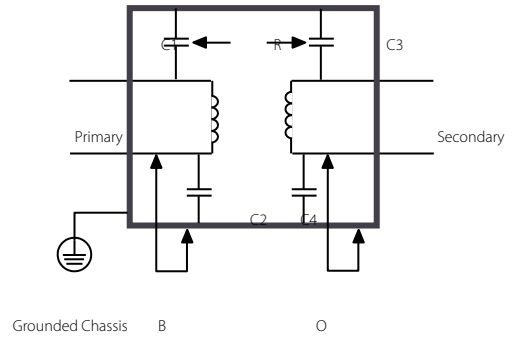

Figure 1: Typical Power Supply Insulation

R – Location of typical Reinforced Insulation

B – Location of typical Basic Insulation

O – Location of typical Operational Insulation

Safety Agency Testing

Testing requirements are categorized into two groups: • Type Testing (Design Verification) • Production Testing

Type Tests

These are the tests which are done by the safety agencies, and are intended to prove that the construction of the power supply meets the requirements dictated by the relevant safety standard.

For IEC/UL60950-1 (ITE) and UL60601-1 (Medical) the requirements are as follows:

60950-1	Primary to Secondary	3000 VAC, or the equivalent DC voltage
	Primary to Grounded chassis	1500 VAC, or the equivalent DC voltage
	Secondary to Grounded chassis	No requirement provided the secondary voltage is less than 42.4 VAC or 60 VDC
60601-1	Primary to Secondary	4000 VAC, or the equivalent DC voltage
	Primary to Grounded chassis	1500 VAC, or the equivalent DC voltage
	Secondary to Grounded chassis	No requirement provided the secondary voltage is less than 42.4 VAC or 60 VDC

Figure 2: Insulation Type Testing Levels

Production Testing

These tests are done as part of the manufacturing process and are intended to ensure integrity of safety critical insulation. Production line testing will be conducted on Basic insulation and on Reinforced insulation during manufacture.

Reinforced (primary to secondary) insulation cannot be tested without over-stressing basic insulation on the end product. (Note: see UL60950-1, C5.2.2 or UL60601-1 2nd Edition Section 20.4 or IEC60601-1 3rd Edition Section 8.8.3 for more information.) Because of this the agencies allow manufacturers to test reinforced insulation separately. This means they are allowed to test transformers and other primary to secondary isolation barriers separately before components are incorporated into the product.

Care is taken that the voltage applied to a REINFORCED INSULATION does not overstress BASIC INSULATION OR SUPPLEMENTARY INSULATION in the EQUIPMENT

Figure 3: UL60601-1 3rd Edition

Only primary to chassis ground (basic insulation) testing is required in production on the final assembly prior to shipping each product.

Type Test (Design Verification Test)

Often times a customer or safety agency engineer wants to verify the type tests on a finished product in the field. This can be done; however, special precautions must be taken to ensure a correct result is achieved. If basic (primary to chassis ground) insulation is to be verified then no special considerations need to be taken. Simply apply a 1500 VAC voltage from Primary AC input to chassis ground. However, if a primary to secondary insulation is to be verified special precautions need to be taken.

Because only basic insulation exists between primary and chassis ground and only operational insulation exists between secondary and chassis ground, any attempt to apply 4000 VAC directly from primary to secondary on the finished product will over stress the primary to chassis ground and secondary to chassis insulation resulting in a failure.

To properly test reinforced insulation the power supply needs to be removed from the chassis. In addition, all paths to chassis ground, as far as practical, need to be removed so as not to over-stress basic and operational insulation during the test.

This usually entails removal of all Y-capacitors and gas discharge tubes and will need interaction with Vox Power Engineering to ensure the correct disassembly. (See Figure 4, right)

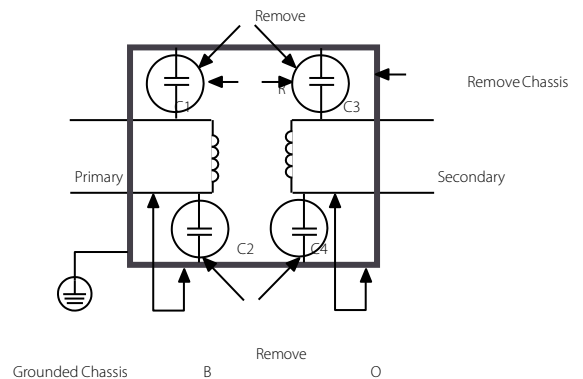

Figure 4: Power Supply disassembly may be required for type testing

Components designed to limit the voltage which may be destroyed by power dissipation during the dielectric strength test may be removed when the test is made.

Figure 5: UL60601-1 3rd Edition

Unfortunately on some products not all paths can be removed. The reason for this is that some printed circuit boards have ground barriers or grounded traces laying between primary and secondary circuitry. Although 'creepage and clearance' requirements are met as specified in the safety standards, these traces, due to proximity, make up small capacitive dividers between secondary traces, floating ground traces and live primary traces. In some instances when applying the primary to secondary hi-pot voltage, some arcing will be observed on the printed circuit boards. In all cases this arcing has been limited to the secondary to grounded trace locations. In some instances this arcing can cause component failure, rendering the power supply inoperable. This is a breakdown of operational insulation (secondary to chassis ground) only. It does not indicate a failure of primary to secondary insulation that is the focus of the test. Provided this 'fails' in a safe manner, the test is considered successful for safety purposes.

Differences for Class II Power Supplies

The previous sections of this document all dealt with power supplies that were of Class I and so had a safety earth ground. Because of this they required hi-pot testing from primary to ground. In the case of Class II power supplies there is no safety ground and so there is no need, nor ability, to test from primary to chassis. Because of the lack of any grounding we also do not have to worry about over stressing any components from the primary to ground side or from the output to ground side. The user is able to simply test from the input to the output on the power supply at 3000 VAC (or 4121 VDC) for ITE devices or 4000 VAC (5656 VDC) for medical devices to verify the insulation in the supply. For further technical information about this article, please contact your local Vox Power representative.